

# Ditec

Last version of this manual  
IP2356EN - 2023-02-14



## Ditec CROSS35

Technical Manual

# Automation for sliding gates

(translation of the original instructions)

# Index

Declaration of incorporation of partly completed machinery .....	4
UK Declaration of Conformity .....	5
<b>1. Technical data .....</b>	<b>6</b>
1.1 Product lifespan .....	8
1.2 Operating instructions .....	9
1.3 Machinery Directive .....	9
<b>2. Installation type .....</b>	<b>10</b>
<b>3. Dimensions .....</b>	<b>11</b>
<b>4. Main components .....</b>	<b>11</b>
<b>5. Installation .....</b>	<b>12</b>
5.1 Preliminary checks .....	12
5.2 Base plate position .....	12
5.3 Installing the gearmotor .....	14
5.4 Adjusting the gearmotor .....	15
5.5 Rack installation .....	16
5.6 Magnetic limit switch installation and adjustment .....	17
<b>6. Electrical connections .....</b>	<b>18</b>
<b>7. Manual release indication .....</b>	<b>20</b>
<b>8. Routine maintenance plan .....</b>	<b>20</b>

## Legend



This symbol indicates instructions or notes relating to safety which require special attention.



This symbol indicates useful information for the correct operation of the product.

# General safety precautions



**ATTENTION!** Important safety instructions. Please follow these instructions carefully.

Failure to observe the information given in this manual may lead to severe personal injury or damage to the equipment. Keep these instructions for future reference.

This manual and those for any accessories can be downloaded from [www.ditecautomations.com](http://www.ditecautomations.com)

This installation manual is intended for qualified personnel only • Installation, electrical connections and adjustments must be performed by qualified personnel, in accordance with Good Working Methods and in compliance with the current regulations • Read the instructions carefully before installing the product. Wrong installation could be dangerous • Before installing the product, make sure it is in perfect condition.



The packaging materials (plastic, polystyrene, etc.) should not be discarded in the environment or left within reach of children, as they are a potential source of danger • Do not install the product in explosive areas and atmospheres: the presence of inflammable gas or fumes represents a serious safety hazard • Make sure that the temperature range indicated in the technical specifications is compatible with the installation site • Before installing the motorization device, make sure that the existing structure, as well as all the support and guide elements, are up to standards in terms of strength and stability. Verify the stability and smooth mobility of the guided part, and make sure that no risks of fall or derailment subsist. Make all the necessary structural modifications to create safety clearance and to guard or isolate all the crushing, shearing, trapping and general hazardous areas • The motorization device manufacturer is not responsible for failure to observe Good Working Methods when building the frames to be motorized, or for any deformation during use • The safety devices (photocells, safety edges, emergency stops, etc.) must be installed taking into account the applicable laws and directives, Good Working Methods, installation premises, system operating logic and the forces developed by the motorized door or gate • The safety devices must protect against crushing, cutting, trapping and general danger areas of the motorized door or gate. Display the signs required by law to identify hazardous areas • Each installation must bear a visible indication of the data identifying the motorized door or gate • Before connecting the power supply, make sure the plate data correspond to those of the mains power supply. An omnipolar disconnection switch with a contact opening distance of at least 3 mm must be fitted on the mains supply. Check that there is an adequate residual current circuit breaker and a suitable overcurrent cutout upstream of the electrical installation in accordance with Good Working Methods and with the laws in force • When requested, connect the motorized door or gate to an effective earthing system that complies with the current safety standards • Before commissioning the installation to the end user, make sure that the automation is adequately adjusted in order to satisfy all the functional and safety requirements, and that all the command, safety, and manual release devices operate correctly.



During maintenance and repair operations, cut off the power supply before opening the cover to access the electrical parts • The protection cover of the operator must be removed by qualified personnel only.



The electronic parts must be handled using earthed antistatic conductive arms. The manufacturer of the motorization declines all responsibility if component parts not compatible with safe and correct operation are fitted • Only use original spare parts for repairing or replacing products • The installer must supply all information concerning the automatic, manual and emergency operation of the motorized door or gate, and must provide the user with the operation and safety instructions

# Declaration of incorporation of partly completed machinery (Directive 2006/42/EC, Annex II-B)

We,  
ASSA ABLOY Entrance Systems AB  
Lodjursgatan 10  
SE-261 44 Landskrona  
Sweden,

declare, under our sole responsibility, that the type of equipment with the name:  
Ditec CROSS35VEISliding gate automations with inverter and magnetic limit switches for industrial  
type entrances with intensive use.

complies with the following directives and their amendments:

2006/42/EC Machinery Directive (MD), regarding the following essential health and safety require-  
ments: 1.1.2, 1.1.3, 1.2.1, 1.2.2, 1.2.3, 1.2.4.2, 1.2.6, 1.3.9, 1.4.3, 1.7.2, 1.7.3, 1.7.4, 1.7.4.1, 1.7.4.2.  
2014/30/EU Electromagnetic Compatibility Directive (EMCD)  
2014/53/EU Radio Equipment Directive (RED)  
2011/65/EU Restriction of Hazardous Substances (RoHS 2)  
2015/863/EU Restriction of Hazardous Substances (RoHS Amendment 2)

Harmonised European standards which have been applied:

EN 61000-6-3:2007 + A1:2011 + AC:2012	EN 61000-6-2:2019
EN 60335-1:2012 + AC:2014 + A11:2014 + A13:2017 + A1:2019 + A14:2019 + A2:2019 + A15:2021	EN 60529:1991 + A1:2000 + A2:2013 + AC:2016
EN 60335-2-103:2015	EN ISO 13849-1:2015
EN 62233:2008 + AC:2008	EN ISO 13849-1:2015
ETSI EN 301 489-1 V2.2.3:2019	ETSI EN 301 489-3 V2.1.1:2019
ETSI EN 300 220-1 V1.2.1:1997	ETSI EN 300 220-2 V3.1.1:2017

Other standards or technical specifications which have been applied:

IEC 60335-1:2010 + C1:2010 + C2:2011 + A2:2013 + C1:2014 + A2:2016 + C1:2016  
IEC 60335-2-103:2006 + A1:2010 EN 12453:2017.

The manufacturing process guarantees that the equipment complies with the technical documenta-  
tion.

Do not put equipment into service until the installed finished Automatic Entrance System has been  
declared compliant with Directive 2006/42/EC on Machinery.

Responsible for the technical documentation:

Matteo Fino  
BSP Ind channel & Gate Automation  
Ditec S.p.A.  
Largo U. Boccioni, 1  
21040 Origgio (VA)  
Italy

Signed on behalf of ASSA ABLOY Entrance Systems AB by:

Place	Date	Signature	Position
Origgio	2023-02-14	Matteo Fino	Head of Ind channel & Gate Automation



# UK Declaration of Conformity

We:

ASSA ABLOY Entrance Systems AB  
Lodjursgatan 10  
SE-261 44 Landskrona  
Sweden

Declare under our sole responsibility that the types of equipment with names:

Ditec CROSS35VEISliding gate automations with inverter and magnetic limit switches for industrial type entrances with intensive use

Comply with the following directives and their amendments:

- Supply of Machinery (Safety) Regulations 2016
- Electromagnetic Compatibility Regulations 2016
- Radio Equipment Regulations 2017
- The Restriction of the Use of Certain Hazardous Substances in Electrical and Electronic Equipment Regulations 2012 (RoHS)

Harmonized European standards that have been applied:

EN 61000-6-3:2007 + A1:2011 + AC:2012  
EN 61000-6-2:2019  
EN 60335-1:2012 + AC:2014 + A11:2014 + A13:2017 + A1:2019 + A14:2019 + A2:2019  
EN 60529:1991 + A1:2000 + A2:2013 + AC:2016  
EN 62233:2008 + AC:2008  
EN ISO 13849-1:2015

Other standards or technical specifications that have been applied:

IEC 60335-1:2010 + C1:2010 + C2:2011 + A2:2013 + C1:2014 + A2:2016 + C1:2016  
EN 12453:2017

The manufacturing process ensures the compliance of the equipment with the technical file.

Responsible for technical file:



Matteo Fino  
BSP Ind channel & Gate Automation  
Ditec S.p.A.  
Largo U. Boccioni, 1  
21040 Origgio (VA)  
Italy

Signed for and on behalf of ASSA ABLOY Entrance Systems AB by:

Place	Date	Signature	Position
Origgio	2023-02-14	Matteo Fino	Head of Ind channel & Gate Automation



# 1. Technical data

	Ditec CROSS35VEI
Power supply	230 V~ 50 / 60 Hz
Motor type	230 V 3~
Power input	4 A
Thrust	3500 N
Gate speed	0.1 - 0.25 m/s
Maximum stroke *	60 m
Pinion	Z15 - Module 6
Gate maximum weight	3500 kg
Service class	VERY HEAVY (tested up to 1,000,000 cycles)
Intermittent operation **	S1= 100% (continuous T= 25°C)
Cycles / hour ***	32 (T= 25°C)
Temperature	
Protection rating	IP55
Electronic panel	LCU43B
Radio frequency	433.92 MHz (code ZENRS) - 868.35 MHz (code ZENPRS)  ZENRS receiver module included, ZENPRS optional.
Noise level L <sub>PA</sub>	≤70 dB (A)
Limit switch	magnetic

\* The maximum stroke of the gate has been calculated considering a default speed of 20 cm/s.

\*\* The declared data are reduced by 50% with T= 55°C.

\*\*\* Cycles are estimated considering a gate with a length of 10 m and factory settings (default speed of 20 cm/s) - see "Chart 1.1".  
**CROSS35VEI** however allows a maximum speed of 25 cm/s (configurable).  
 Each cycle is considered an opening manoeuvre followed by a closing manoeuvre.

Chart 1.1

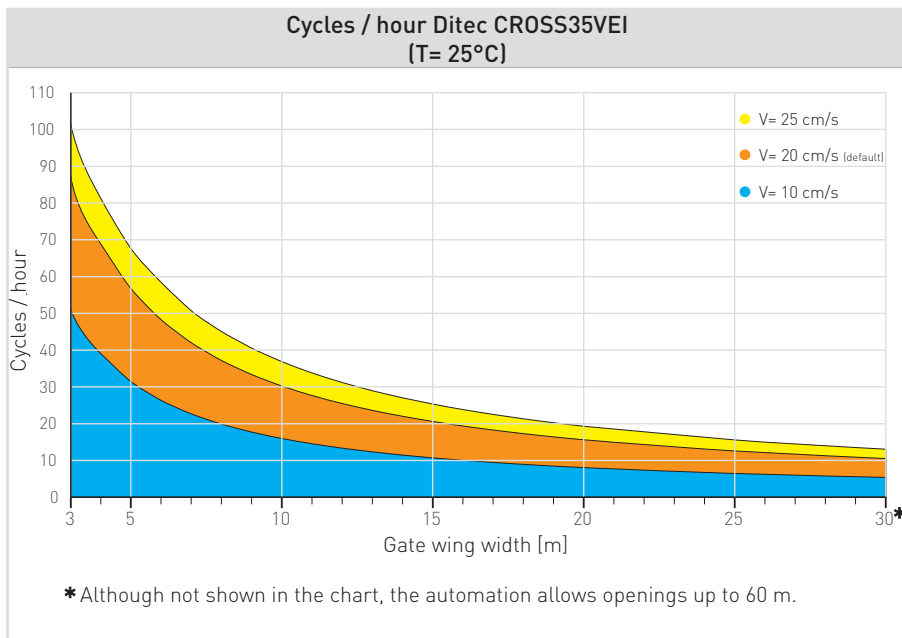

Indicative cycles considering the factory settings and some speeds that can be configured on CROSS35VEI.

Cycle refers to an opening operation followed by a closing operation.

## 1.1 Product lifespan

The product lifespan is conditioned by the extent of other onerous conditions: with reference to Tab. 1.1, various corrective factors have been assessed in relation to the weight and width of the gate wing and the usage conditions; when taken as a whole, they affect the lifespan of the object (see Chart 1.2).

Tab. 1.1

Index of conditioning factors		Ditec CROSS35VEI
Gate wing weight	1750 Kg	-
	>2000 Kg	10
	>2500 Kg	20
	>3000 Kg	30
Gate wing width	>10 m	10
	>20 m	20
Wheels diameter <100 mm		10
Saline environment		10
Installed safety edge		10
VA/VC speed setting higher than the default values		10
OB/CB slowdown distance setting lower than the default values		
R1/R2/DT force setting higher than the default values		10

Graph. 1.2

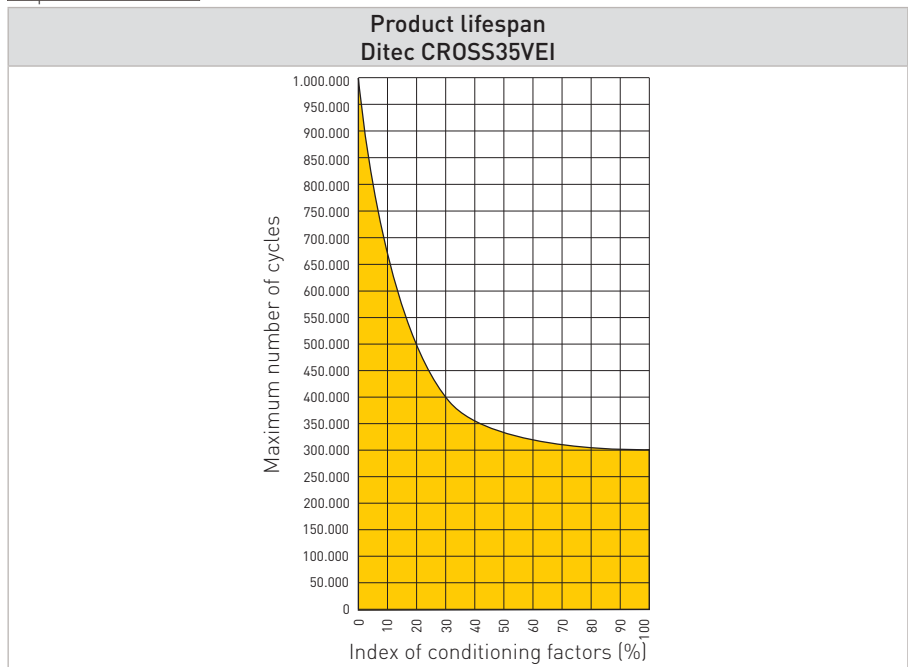



## 1.2 Operating instructions

**USE:** for condominium, industrial and commercial, car park entrances with heavy driveway or pedestrian use.

- Not suitable for gates or doors incorporating pedestrian auxiliary doors.
- The class of service, usage times and number of consecutive cycles are suggestions. They are statistically measured under average usage conditions and cannot be certain for every single case.
- For each automatic entrance, there are variables such as friction, balancing and environmental conditions that can substantially change the operating life and quality of the automatic entrance or some of its components (including the automated mechanisms). It is up to the installer to implement safety factors appropriate for each particular installation.

## 1.3 Machinery Directive

According to the Machinery Directive (2006/42/EC), the installer who motorises a door or gate has the same obligations as the manufacturer of a machine, and as such must:

- prepare the technical documentation, which must contain the documents indicated in Annex V of the Machinery Directive;  
(the technical documentation must be kept and made available to the competent national authority for at least ten years, starting from the date of construction of the motorised door);
- draw up the EC statement of conformity according to Annex II-A of the Machinery Directive and hand it over to the customer;
- affix the CE marking to the motorised door in accordance with point 1.7.3 of Annex I of the Machinery Directive.

## 2. Installation type

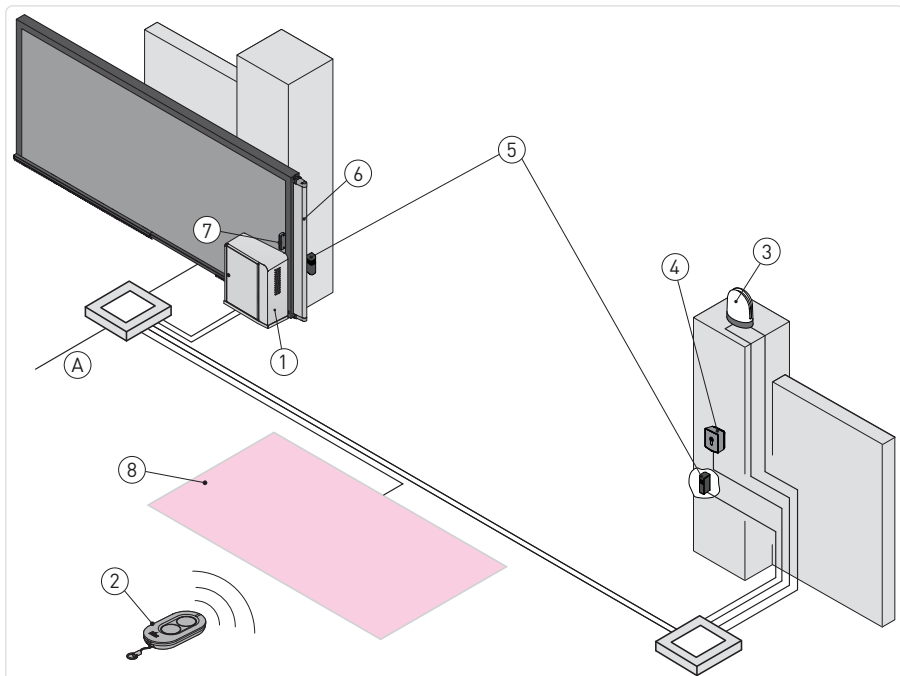

Ref.	Code	Description	Cable
1	Ditec CROSS35VEI	Automation with magnetic limit switches / built-in control panel	3G x 1.5 mm <sup>2</sup>
2	ZEN	Transmitter	/
3	FLM FL24	Flashing light Antenna (integrated in the flashing light)	2 x 1 mm <sup>2</sup> RG-58 coax cable (50 Ω)
4	AXK4 AXK5M AXK5N AXK5NM AXK5NI AXR7	Digital combination wireless keypad Wall-mounted key-operated selector switch with European cylinder Semi-recessed key-operated selector switch with European cylinder Wall-mounted key-operated selector switch without cylinder Semi-recessed key-operated selector switch without cylinder RFID reader unit	/ 4 x 0.5 mm <sup>2</sup> 5 x 0.5 mm <sup>2</sup>
A		Connect the power supply to a certified-compliant omnipolar switch (not included) with a contact opening distance of at least 3 mm. Connection to the mains must be via an independent conduit, separated from the connections to the command and safety devices.	
5	LIN2 LIN2B AXP2 LAB4	Photocells	4 x 0.5 mm <sup>2</sup>
6	SOFAP20 SOF2M20-SOF3M20 SOFA15-SOFA20-SOFA25	Safety edge	2 x 0.5 mm <sup>2</sup> min
7	GOPAV	Radio system for sensitive edges	/
8	LAB9	Magnetic loop	2 x 1.5 mm <sup>2</sup>

### 3. Dimensions

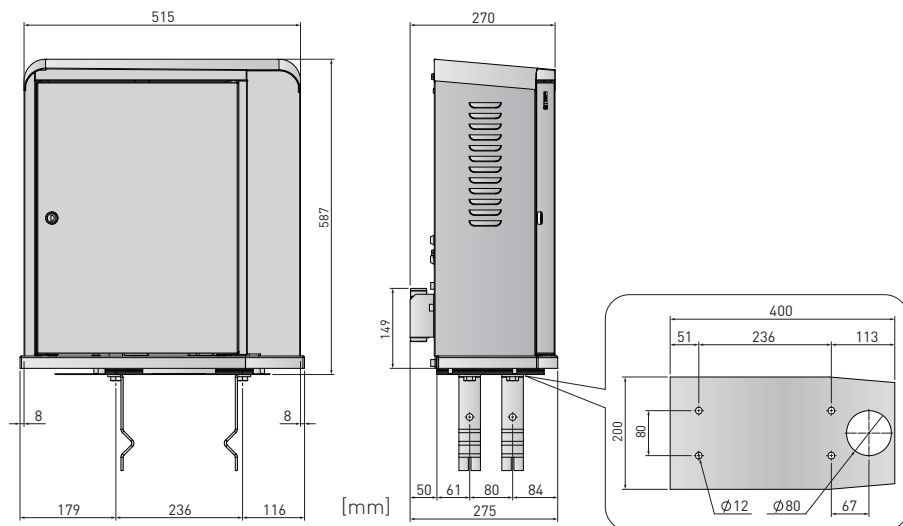

### 4. Main components

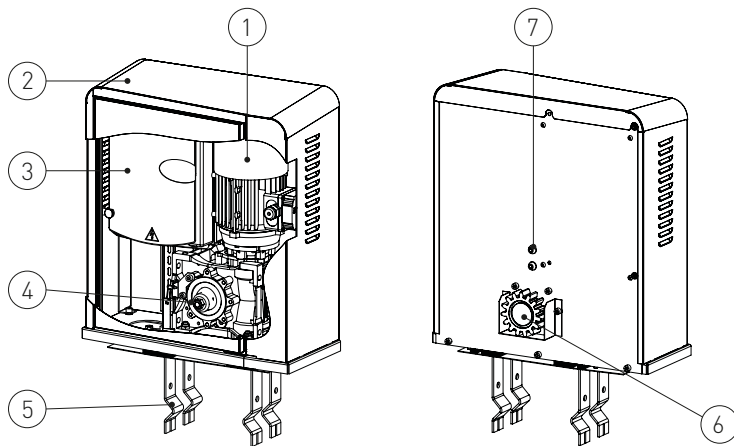

Ref.	Description
1	Motor
2	Cover
3	Control panel
4	Manual release
5	Anchor ties
6	Lever limit switch unit
7	Magnetic limit switch unit

# 5. Installation

Guaranteed operation and stated performance can only be achieved with DITEC accessories and safety devices.

All measurements shown are in mm, unless otherwise indicated.

## 5.1 Preliminary checks

Check the stability of the wing (derailment and side falls) and the condition of the running wheels and that the upper guides do not create friction.

The runner should be firmly anchored to the ground, fully exposed along its entire length and should not have any irregularities that could hinder the movement of the wing.

Opening and closing stops must be installed.

If the gate has gaps, these should be covered to eliminate shearing points.

Safety devices should be installed at the ends of the wing to reduce impact forces.

**i NOTE:** Check that the gate cannot fall out of the guides.

## 5.2 Base plate position

- Insert the anchor ties onto the base plate and fix them with the supplied nuts.
- Prepare a concrete base with the anchor ties and base plate embedded, which must be level and clean, following the measurements indicated in the diagram.

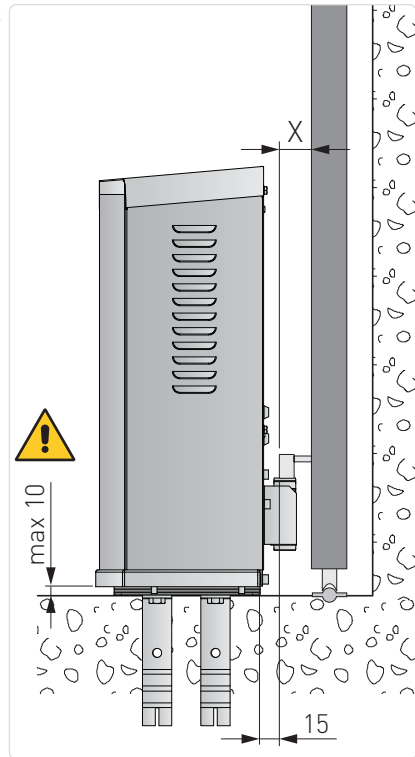

- Opening to the left

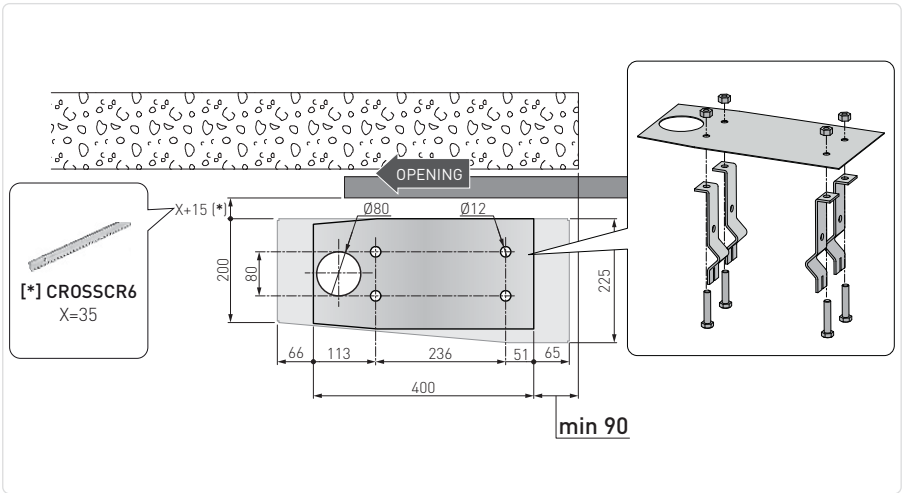

- Opening to the right

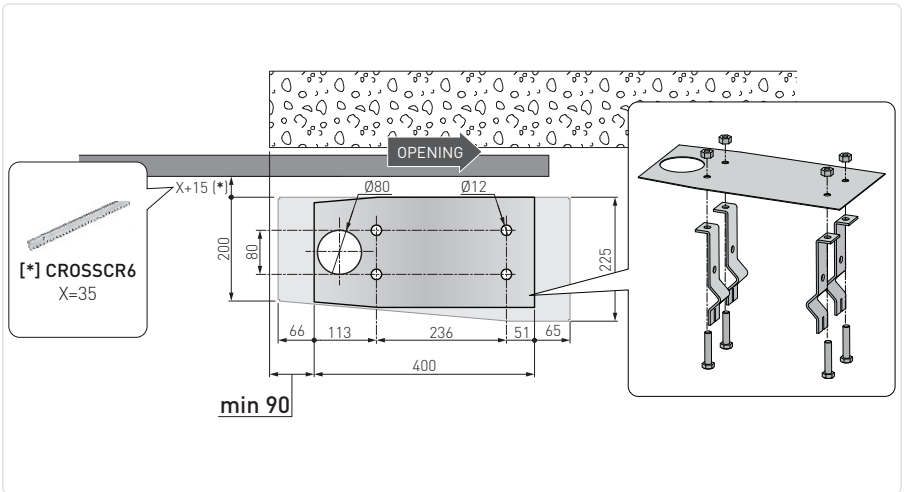

## 5.3 Installing the gearmotor

- Open the gearmotor window. Unscrew the three screws [A] (the top screw must not be completely unscrewed) and remove the cover.

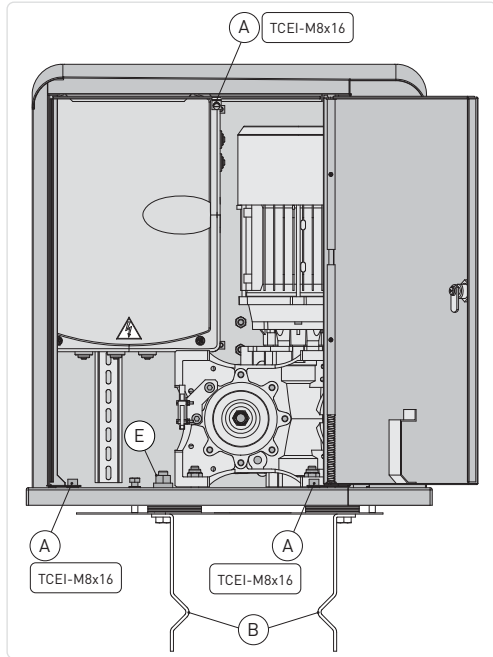

- Before placing the gearmotor on the base plate (C), remove the nuts (E) - used to fasten the ties (B).
- Partially screw on the nuts (E).

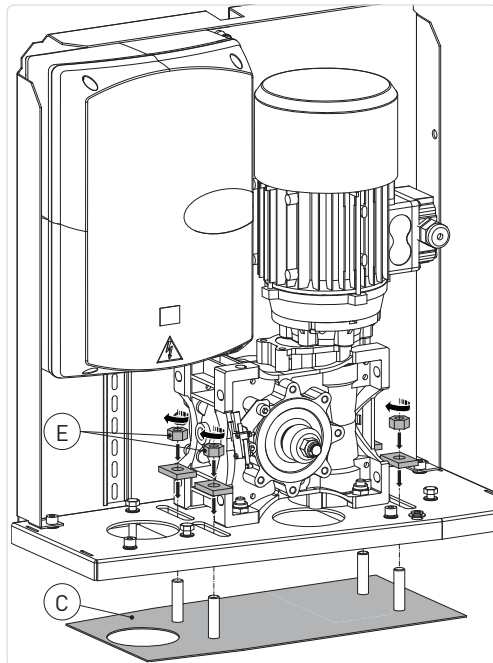

## 5.4 Adjusting the gearmotor

- Horizontally, sliding it on the slots in the gearmotor base (G) ( $\pm 20$  mm).

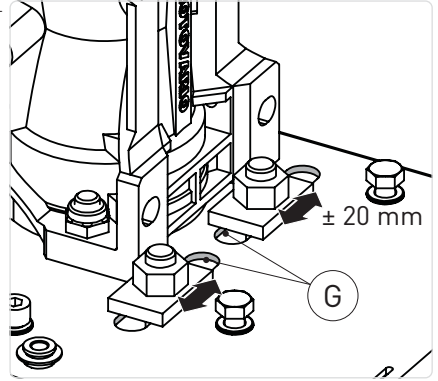

- Vertically, using the four levelling screws [H] and inserting the spacers supplied [D].

If the rack is already installed, keep the gearmotor slightly raised from the base plate so that the rack can be fixed and subsequent adjustments are possible.



**NOTE:** after inserting the levelling spacers [D], loosen the screws [H], the motor must rest only on the spacers [D]. Fasten the nuts [E].



**WARNING:** the gearmotor must be suitably raised from the ground to avoid flooding (vertical adjustment of the base max. 10 mm).

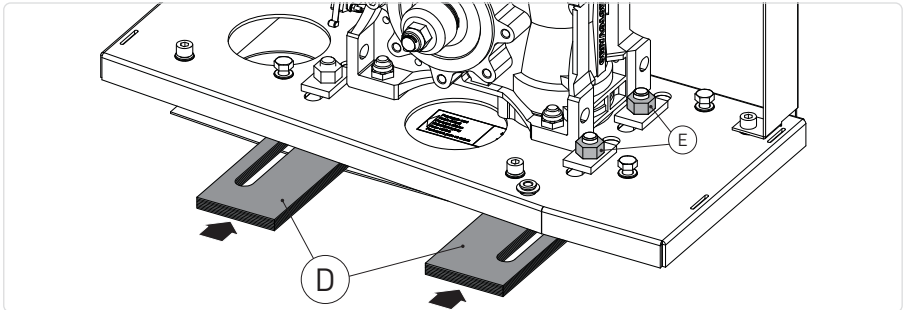
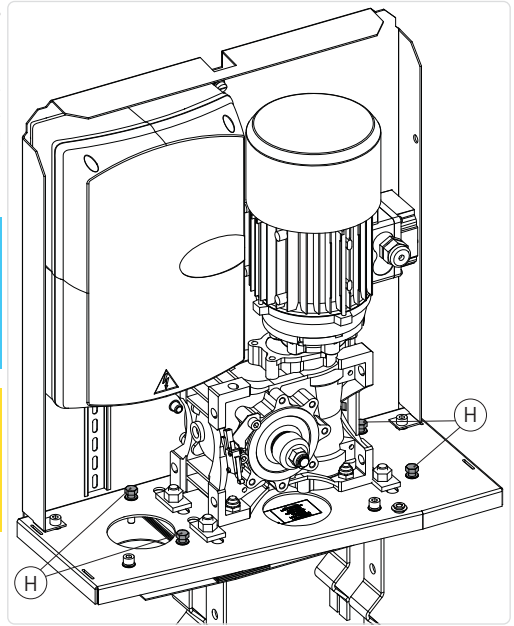

## 5.5 Rack installation

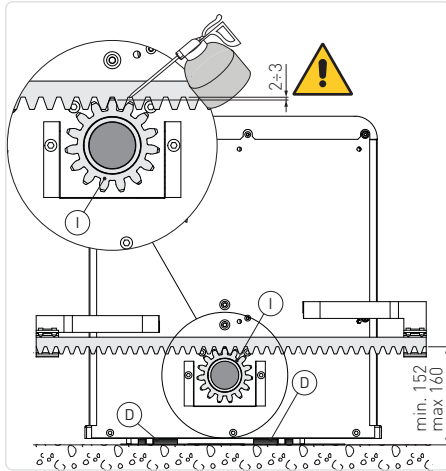

**WARNING:** use a rack module 6.

- Release the gearmotor (see paragraph 7) and open the gate.
- Rest the rack onto the pinion [I] and manually sliding the gate, fix it throughout its entire length.

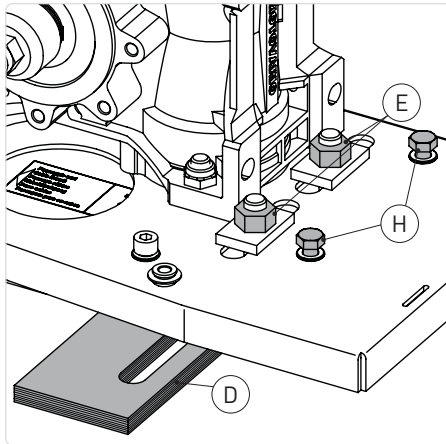

- Once fixed, vertically adjust the gearmotor (using screws [H] ) to give a play of about 2-3 mm between the pinion and the rack.
- Secure the gearmotor with the nuts [E].



**WARNING:** having completed the adjustments, the motor must rest only on the spacers [D].

- Slightly lubricate the rack and pinion after assembly. Manually check that the gate slides evenly and without friction.



## 5.6 Magnetic limit switch installation and adjustment

- Manually place the wing in the completely open position and fix the limit switch bracket [K] onto the rack so that the limit switch exceeds for  $1/3$  times the length of the bracket. Repeat the operation with the wing fully closed.
- After having carried out a few manoeuvres,

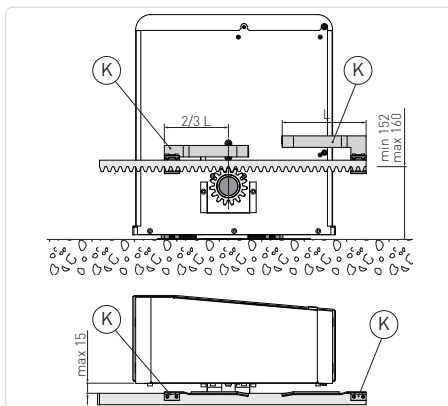

adjust the position of the limit switch bracket [K] so that the gate stops about 20 mm before the opening and closing stop.

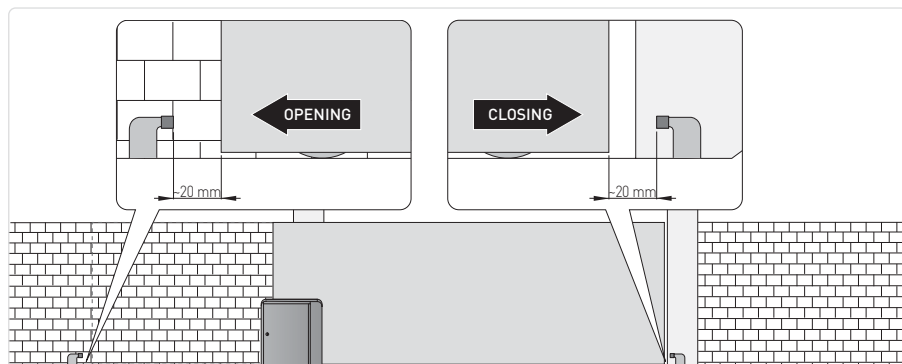

## 6. Electrical connections



**NOTE:** the electrical wiring and the start-up of the gearmotors are shown in the control panel installation manuals.

Before connecting the power supply, make sure that the data on the plate correspond to the electricity distribution network data. Provide an omnipolar switch/disconnector on the power network with a contact opening distance of 3 mm or more. Check that there is a suitable residual-current device and surge protector upstream of the electrical system. Use an H05RN-F 3G1.5 electrical cable and connect it to terminals L (brown) and N (blue) inside the automation system. Connect the earth cable  (yellow/green) to the earth terminal.



**ATTENTION:** always observe L-N polarity when connecting to the mains.

Secure the cable by means of the cable clamp and only unsheathe it at the terminal.

Connections to the electrical distribution network and any other low-voltage conductors (230 V), in the section outside the automation system, must be made with corrugated pipes that are independent and separate from the path of connections to the control and safety devices (SELV = Safety Extra Low Voltage). Make sure there are no sharp edges that could damage the power cord.



Ensure that the mains connection cables, any other low-voltage cables (230 V), and safety extra-low voltage safety accessory connection cables in the portion located inside the product are kept well separated from the gear motor body.

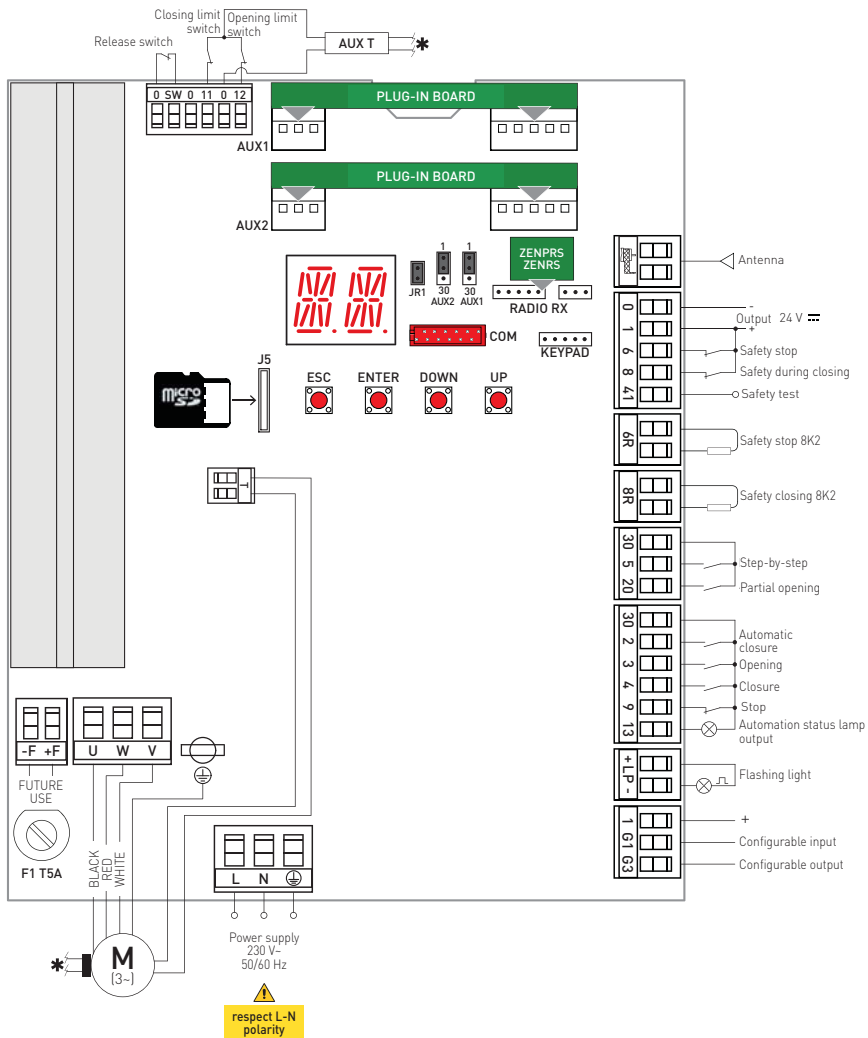

For complete control panel instructions see manual LCU43A - LCU43B IP2336:



<https://www.ditecautomations.com/global/market-documents/QR/QE/LCU43.pdf>

## 7. Manual release indication

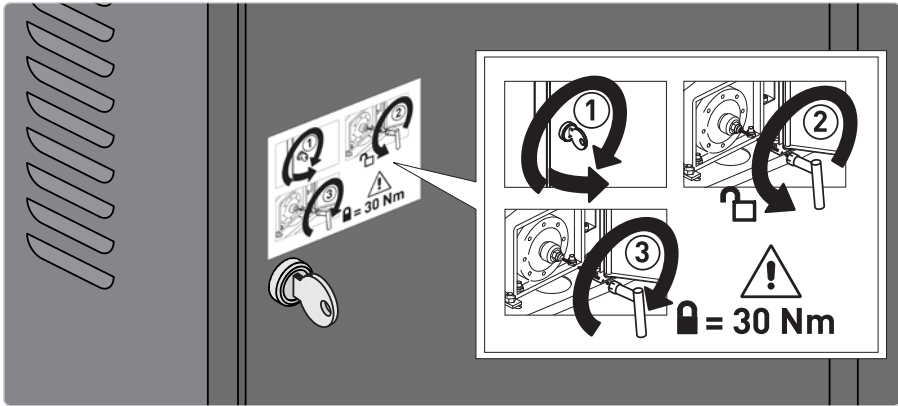

## 8. Routine maintenance plan

Carry out the following operations and checks every 6 months, depending on the how much the automation system is used.

Switch off the 230 V- power supply and unlock the gear motor:

- Visually check that the gate, the fixing brackets and the existing structure have the necessary mechanical strength and are in good condition.
- Check the gate-motor alignment and the distance (2-3 mm) between the pinion groove and the rack crest.
- Clean the wheel guides, rack and pinion of the gear motor and lightly lubricate the rack and pinion of the gear motor. Manually check that the gate slides smoothly and without friction. Switch on the 230 V- power supply and lock the gear motor:
  - Check that the limit switches work correctly.
  - Check force settings.
  - Check the correct operation of all control and safety functions.



**NOTE:** For spare parts, please see the spare parts list.

All the rights concerning this material are the exclusive property of ASSA ABLÖY Entrance Systems AB. Although the contents of this publication have been drawn up with the greatest care, ASSA ABLÖY Entrance Systems AB cannot be held responsible in any way for any damage caused by mistakes or omissions in this publication. We reserve the right to make changes without prior notice.

Copying, scanning or changing in any way is expressly forbidden unless authorised in writing by ASSA ABLÖY Entrance Systems AB.

 The crossed-out wheellie bin symbol indicates that the product should be disposed of separately from normal household waste. The product should be recycled in accordance with local environmental regulations for waste disposal. By separating a product marked with this symbol from household waste, you will help reduce the volume of waste sent to incinerators or land-fill and minimise any potential negative impact on human health and the environment.



ASSA ABLÖY Entrance Systems AB  
Lodjursgatan 10  
SE-261 44, Landskrona  
Sweden  
© ASSA ABLÖY